

GMM220 Carbon Dioxide Modules for Demanding OEM Applications



The Vaisala CARBOCAP® Carbon Dioxide Module Series GMM220 withstand harsh conditions. They provide high carbon dioxide measurement accuracy over wide temperature and relative humidity ranges.

Features/Benefits

- Incorporates Vaisala CARBOCAP® Sensor - the silicon based NDIR sensor
- Choice of several measurement ranges
- IP65 protected probe against dust and spray water
- Interchangeable probes provide easy maintenance

For harsh environments

The Vaisala CARBOCAP® Carbon Dioxide Module Series GMM220 are designed for Original Equipment Manufacturers (OEM's) requiring carbon dioxide measurements in harsh and demanding applications.

The modules are optimized for integration into equipment for greenhouse control, incubators, fermentors, safety alarming and integrated systems.

Vaisala CARBOCAP® – the silicon based CO₂ sensor

The GMM220 series modules incorporate the industrial Vaisala CARBOCAP® Sensor. The patented sensor has unique reference measurement capabilities. Its critical parts are made of silicon; this gives the sensor outstanding stability over both time and temperature.

Since water vapor, dust, and most chemicals do not effect the measurement, the GMM220 series modules can be used in harsh and humid environments.

Interchangeable probes

The GMP220 probes are interchangeable. They can be removed, reattached or replaced at any time – without the need for calibration and adjustment. The interchangeable probes make calibration and field service easy. In addition, the measurement range can be changed simply by replacing one probe with another.

Different configurations to meet demanding applications

The user has a choice of measurement ranges up to 20 % CO₂; the Vaisala CARBOCAP® Carbon Dioxide Module GMM221 for higher and the Vaisala

CARBOCAP® Carbon Dioxide Module GMM222 for lower concentrations of CO₂.

Different power supply voltages, output options, as well as cable lengths, connectors, and mounting gear are also available.

Technical Data

Carbon Dioxide

Measurement Ranges	
GMM221	0...2 %
for high concentrations	0...3 %
	0...5 %
	0...10 %
	0...20 %
GMM222	0...2000 ppm
for low concentrations	0...3000 ppm
	0...5000 ppm
	0...7000 ppm
	0...10 000 ppm
Accuracy (including repeatability, non-linearity and calibration uncertainty) at 25 °C and 1013 hPa	
GMM221	±(1.5% of range + 2% of reading)
(applies for concentrations above 2% of full scale)	
GMM222	±(1.5% of range + 2% of reading)
Temperature dependence, typical	-0.3 % of reading / °C
Pressure dependence, typical	+0.15% of reading/hPa
Long-term stability	<±5 %FS/2 years
Response time (63 %)	
GMM221	20 seconds
GMM222	30 seconds
Warm-up time	30 seconds, 15 minute full specifications

Inputs and outputs

Outputs	0...20 or 4...20 mA
	0...1 V, 0...2 V, 0...2.5 V, or 0...5 V
Resolution of analog outputs	12 bits
Recommended external load:	
current output	max. 200 Ohm
voltage output	min. 1 kOhm
Relay contacts	max. 30VAC/60VDC, 0.5A
Operating voltage	11...20 VDC or 18...30 VDC
Power consumption	<2.5 W

Operating environment

Operating temperature	-20...+60 °C
Storage temperature	-30...+70 °C
Operating pressure	700...1300 hPa
probe	0...100 %RH, non-condensing
mother board	0...85 %RH, non-condensing
Electromagnetic compability	EN61326-1, Generic Environment

Mechanics

Probe housing material	PC plastic
Housing classification (probe only)	IP65
Weight:	
GMM221 (w/2m cable)	max. 180 g
GMM222 (w/2m cable)	max. 200 g
Probe cable length	0.6 m, 2 m, 6 m or 10 m (optional)

Accessories

Spare probe	GMP221, GMP222
(use the order form to define measurement range etc.)	
Clips (2 pcs) for attaching the probe	25245GM
Mounting flange for the probe	GM45156
Probe cables	
2 m probe cable	GMP343Z200SP
6 m probe cable	GMP343Z600SP
10.0 m probe cable	GMP343Z1000SP
Serial COM adapter	19040GM

Dimensions

Dimensions in mm (inches)

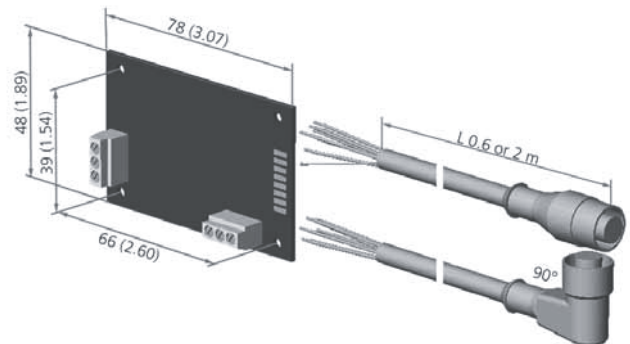

CARBOCAP® is a registered trademark of Vaisala.
 Specifications subject to change without prior notice.
 ©Vaisala Oyj

